



**185,000 Gallon per day capacity
Seawater Reverse Osmosis with HPB Energy Recovery System**

STANDARD FEATURES

- ◆ Duplex Stainless Steel Positive displacement type high pressure pumps
- ◆ Duplex Stainless Steel Horizontal multi-stage centrifugal pumps
- ◆ 1000PSI side ports design FRP pressure vessels to reduce the manufacturing of high pressure piping.
- ◆ 400 sq. ft. high rejection thin film composite low pressure seawater Reverse Osmosis membranes
- ◆ Hydraulic Pressure Booster to greatly increase the efficiency of the unit by harnessing the energy of the reject brine
- ◆ System Interlocks for Pre and Post chemical feed systems, raw water and backwash pumps, multimedia filters, raw and product water tank levels
- ◆ Variable Frequency drive (VFD) to run the RO high pressure pumps
- ◆ NEMA 4X PLC based electrical control panel with Man Machine Interface (MMI) panel view or Selector switches
- ◆ Plastic Construction Five Micron Filter

- ◆ Automatic inlet shut-off valve
- ◆ Reject by pass fine tuning valve
- ◆ Auto flush valve
- ◆ Sample valves for each pressure vessel product
- ◆ Cartridge filter inlet and outlet liquid filled pressure gauges
- ◆ Membrane feed, reject and product liquid filled pressure gauges
- ◆ High pressure pump low and high pressure switch
- ◆ Raw water feed and product flow indications
- ◆ RO permeate conductivity meter
- ◆ Powder coated steel skid
- ◆ 316L SS or Duplex SS High pressure & PVC Low pressure piping

Bauer International Corporation BIC SW Series Reverse Osmosis Systems are designed using the high quality selected components.

The Reverse Osmosis unit can be built based on the customer's requirements especially where space is limited. A containerized seawater Reverse Osmosis unit can be built where easy site installation and mobilization of equipment is required.

The seawater Reverse Osmosis system is built with an Energy recovery device, since the energy is the largest cost of operating a desalination plant. The Hydraulic Pressure Booster or HPB is a fully self-contained brine energy recovery device for seawater and brackish water systems. With over 400 units in field service, the HPB has earned a reputation for reliability, ease of operation and most importantly as the best value in energy recovery today.

The HPB generates a pressure boost in the feed stream ranging from 20 to 40% of the total membrane requirement. The unit is entirely energized by the brine stream. The brine and feed provide all lubrication and cooling. The HPB includes an integral valve for brine pressure regulation.

The Multi-stage centrifugal high pressure feed pumps have proved to be the most reliable high pressure feed pump available today. Loaded with unique features such as the patented water bearing (thrust bearing), pure page lubricated bearings and overhaul friendly design ensures years of trouble free operation.

Bauer International Corporation standard package seawater Reverse Osmosis ranges from 100 cubic meter per day (26,420 Gallons per day) to 719 cubic meter per day (190,000 Gallons per day). Custom design systems are also available and can be supplied with filtration systems, pre & post treatment chemical feed systems and membranes cleaning system to meet your specific plant requirements. At Bauer International Corporation, we provide an engineering innovations, creativity and expertise to help you select the right equipment and engineering design for your specific needs.

AVAILABLE OPTIONS

- ◆ Pretreatment and Post treatment Chemical Feed systems
- ◆ Manual or Automatic Multimedia filter
- ◆ Manual or Automatic Activated Carbon Filter
- ◆ Raw water and filter backwash feed pumps
- ◆ RO Membrane cleaning system
- ◆ RO plant fresh water flush system
- ◆ Choices of Energy recovery systems (Energy Recovery Turbo Charger, Pelton Wheel or Pressure Exchanger)
- ◆ Duplex Stainless Steel, 904L SS, or Super Duplex SS
- ◆ Feed and product pH indicator
- ◆ Feed ORP indicator
- ◆ Feed conductivity indicator
- ◆ Feed water TDS of more than 36,000 PPM

Technology and Experience Bring Satisfaction

Model No.	Capacity GPD	Total Membranes	Total Pressure Vessel	Feed Flow GPM	Feed Pressure PSI	Reject Flow GPM	Reject Pressure PSI	System Recovery	Horse Power (HP)
BIC-SW-804028	30,000	8	2	60	630	39	620	35%	40
BIC-SW-8040210	40,000	10	2	70	660	42	650	40%	40
BIC-SW-8040315	60,000	15	3	105	660	62	650	50%	50
BIC-SW-8040420	80,000	20	4	112	710	56	700	50%	60
BIC-SW-8040424	100,000	24	4	139	760	70	750	50%	75
BIC-SW-8040530	120,000	30	5	167	730	84	720	50%	100
BIC-SW-8040636	150,000	36	6	209	760	104	750	50%	100
BIC-SW-8040848	190,000	48	8	264	760	132	750	50%	125

Notes:

1. Results may vary depending on the feed water analysis.
2. Pre-treatment required contingent upon feed water analysis.
3. Flows is based on temperature of 25°C
4. Feed water suction pressure shall not be less than 29PSI
5. Feed water TDS is based on 32,000ppm
6. Reverse Osmosis membrane GFD is based on 10 GFD
7. Seawater Reverse Osmosis membrane is based on 400 sq. ft. low pressure type.
8. Reverse Osmosis projection is based on 3 years operation

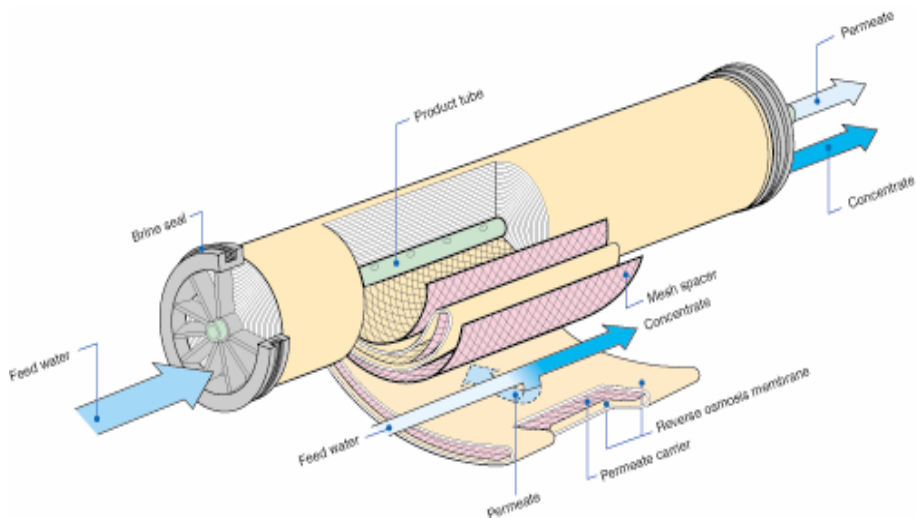

BAUER INTERNATIONAL CORPORATION
WATER AND WASTEWATER TREATMENT SYSTEMS

1542 Edinger Avenue, Suite D, Tustin, CA 92780 U.S.A.

Tel: (714) 689-9055

Fax: (714) 689-9056

www.bauerusa-intl.com

E-mail: info@bauerusa-intl.com