

BIC PTF20000 series Package Type Filtration system is designed cost-effectively for small municipal applications. Package Type Water Filtration systems are most appropriate for plant sizes from 20,000 to 60,000 Gallons per day (GPD). This unit is most widely used to treat surface water supplies for removal of turbidity, color, and coliform organisms with filtration processes. They can also be applied to treat contaminants such as iron and manganese in groundwater via oxidation and filtration. These systems comply with The Surface Water Treatment Rule (SWTR) requirements, and they are also cost-effective solutions for tight budgets.

OPERATION AND MAINTENANCE

Package Type Water Filtration System operation is simplified by automated features such as effluent turbidimeters connected to chemical feed controls and other operating parameters, such as backwashing. Chemical feed controls are especially important for plants without full-time operators or with variable influent characteristics. Maintenance requirements are well documented in manuals.

TECHNICAL SPECIFICATIONS

- ◆ 20,000 LPH Package Filtration System components
- ◆ Flash mix chamber, 5M3 capacity, 304 SS Construction
- ◆ Flocculation chamber, 5m3 Capacity, 304 SS Construction
- ◆ Coagulant chamber rapid speed mixer, 3/4 HP, 220V
- ◆ Inclined plate clarifier, 304 SS construction chamber and plate pack
- ◆ Mixed Media Gravity filters, 304 SS Construction
- ◆ Clear water and backwash storage tank, 30 m3 capacity (Supplied by Client)
- ◆ Filter Backwash Feed Pump
- ◆ Sludge Dewatering System Components (optional)

FEATURES AND BENEFITS

- ◆ Pre-engineered design
- ◆ Factory Assembled
- ◆ Flocculation, Coagulation plate settling chamber and mixed media filter all in one module
- ◆ High rate mixed Media Filtration
- ◆ Minimizes design cost
- ◆ Minimizes installation costs and time
- ◆ Highly Mobile
- ◆ Automatic Operation
- ◆ Smaller footprint
- ◆ Long filter runs
- ◆ Better effluent quality



Package Type Water Filtration System

BIC PTF20000

Typical Flow Diagram

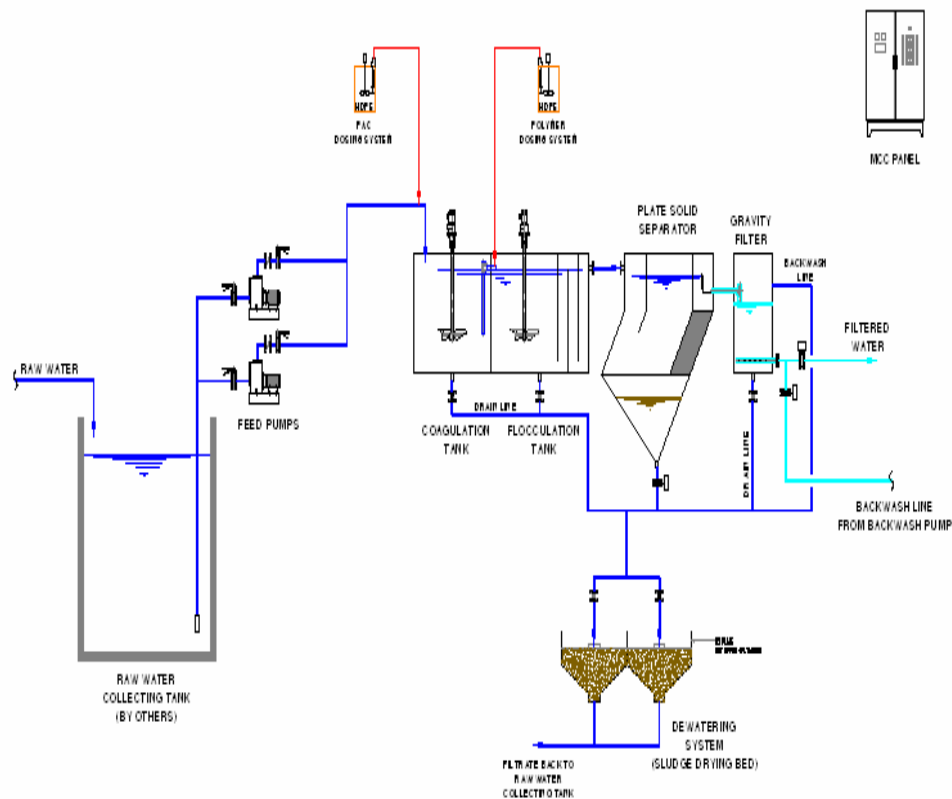

BAUER INTERNATIONAL CORPORATION

WATER AND WASTEWATER TREATMENT SYSTEMS

1542 Edinger Avenue, Suite D, Tustin, CA 92780 U.S.A.

Tel: (714) 258-7260

Fax: (714) 258-7274

www.bauerusa-intl.com

E-mail: sales@bauerusa-intl.com

Package Type Water Filtration System

BIC PTF20000

Typical Arrangement Drawings

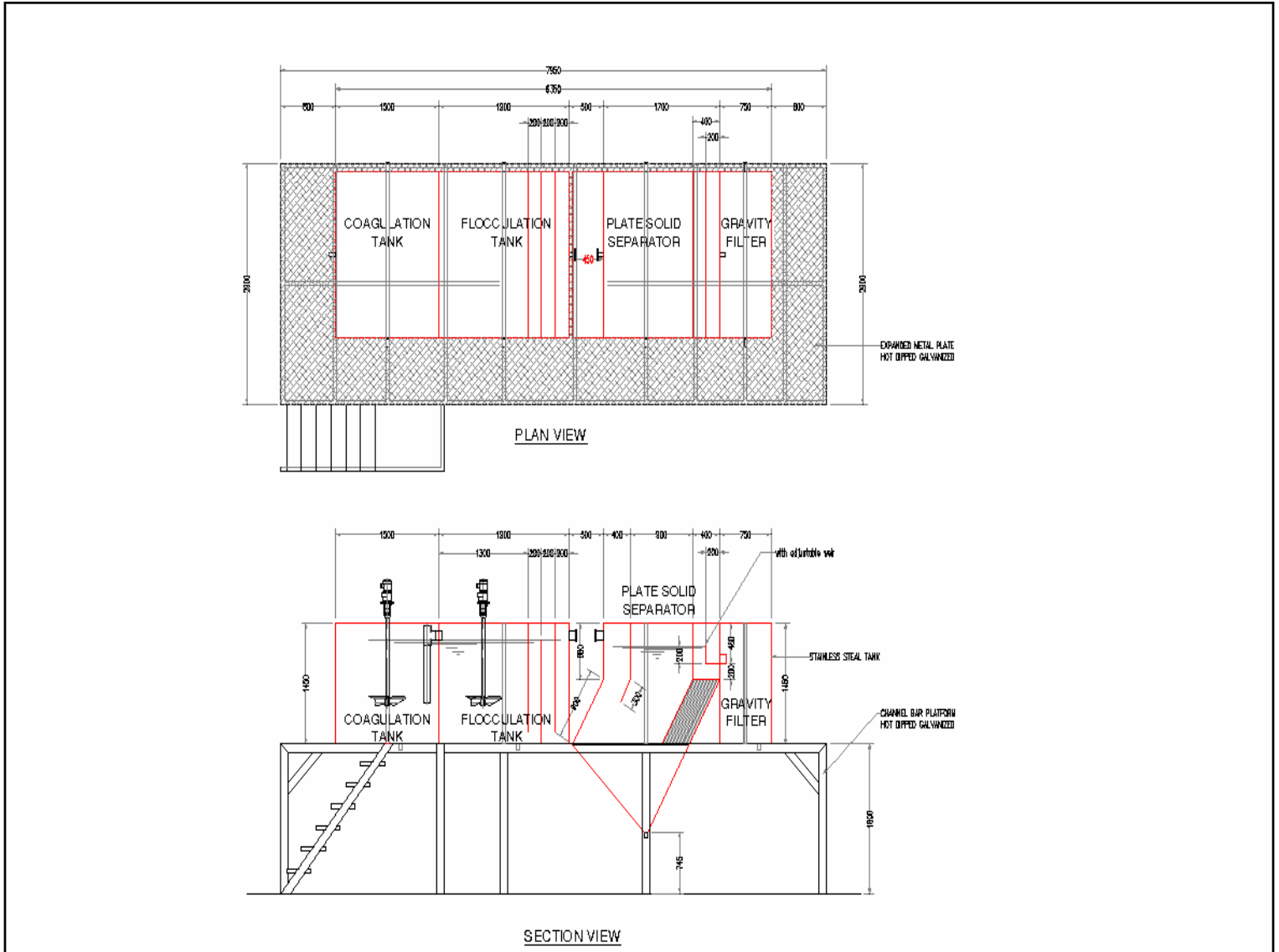

BAUER INTERNATIONAL CORPORATION

WATER AND WASTEWATER TREATMENT SYSTEMS

1542 Edinger Avenue, Suite D, Tustin, CA 92780 U.S.A.

Tel: (714) 258-7260

Fax: (714) 258-7274

www.bauerusa-intl.com

E-mail: sales@bauerusa-intl.com